

THIS DRAWING IS UNPUBLISHED. RELEASED FOR PUBLICATION  
 © COPYRIGHT - BY TYCO ELECTRONICS CORPORATION. ALL RIGHTS RESERVED.

LOC	DIST	REVISIONS					
G	14	P	LTR	DESCRIPTION	DATE	DWN	APVD
		L1		REV PER ECR 08-012669 & 08-012651	30MAY08	JR	TM

<b>AMP</b> WIRE RANGE	Listed	LR7189 Certified
16-14 AWG SOLID OR STRANDED	16-14 AWG SOLID OR STRANDED	16-14 AWG SOLID OR STRANDED

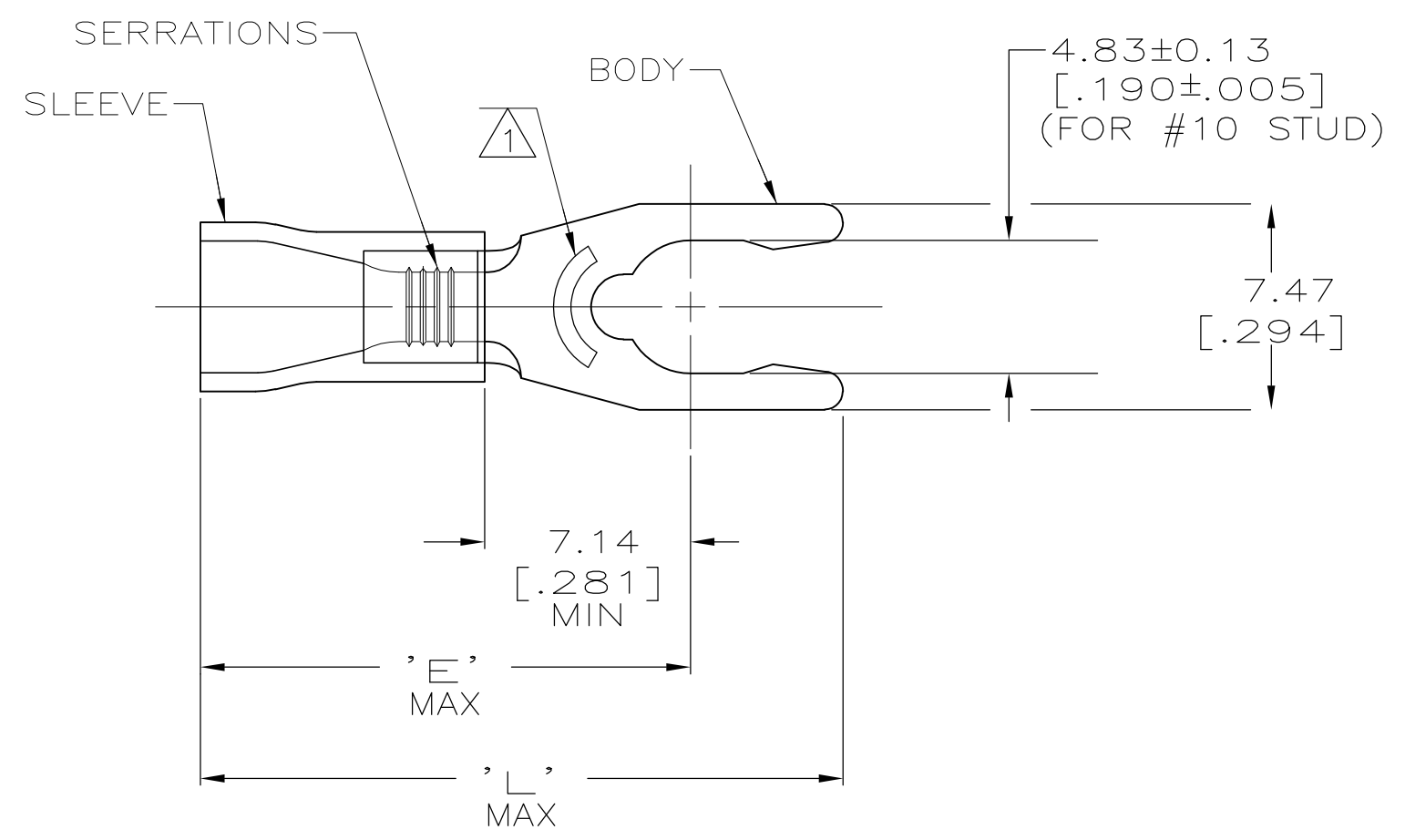

- 1 STAMP 10S AMP 16-14\* APPROX AS SHOWN
- 2 SEE TABLE FOR WIRE INSUL DIA
- 3 TONGUE MATERIAL THK IS 0.79±0.05 [.031±.002].
- 4 MATERIAL: BODY - BRASS PER ASTM B-36  
SLEEVE - PVC, COLOR - BLUE

24.61 [.969]	18.95 [.746]	.150 - .250	2500	ON TAPE, REEL	53245-6
23.37 [.920]	17.70 [.697]	.118 - .195	5000	ON TAPE, REEL	53245-2
			1000	LOOSE PIECE	53245-1
"L"	"E"	WIRE INSUL DIA	QTY	PACKAGE TYPE	PART NO.

<b>AMP INCORPORATED CUSTOMER SERVICE SYSTEMS</b>		MAX RECOMMENDED OPERATING TEMPERATURE: 105°C [221° F]
FOR ADDITIONAL PRODUCT INFORMATION OR COPIES OF DRAWINGS AND TECHNICAL DOCUMENTS	PRODUCT INFORMATION CENTER 1-800-522-6752	VOLTAGE RATING: 600V MAX (1000V FIXTURE OR SIGN)
FOR APPLICATION TOOLING INFORMATION	TOOLING ASSISTANCE CENTER 1-800-722-1111	CIRCULAR MIL AREA: 1.04-2.62mm² [2,050-5,180] SOLID OR STRANDED
FOR ORDER ENTRY 1-800-526-5142	THIS DRAWING IS A CONTROLLED DOCUMENT FOR AMP INCORPORATED. IT IS SUBJECT TO CHANGE AND THE CONTROLLING ENGINEERING ORGANIZATION SHOULD BE CONTACTED FOR THE LATEST REVISION.	

THIS DRAWING IS A CONTROLLED DOCUMENT.	
DIMENSIONS: MM[INCHES]	TOLERANCES UNLESS OTHERWISE SPECIFIED:
	0 PLC ± - 1 PLC ± - 2 PLC ± 0.20[.008] 3 PLC ± - 4 PLC ± - ANGLES ± -
MATERIAL	FINISH
	TIN PER ASTM B545

DWN DK SCHRUM 12/11/92	Tyco Electronics Corporation Harrisburg, Pa 17105-3608	
CHK RE HERSEY 1/4/93	NAME M BARNABA	
APVD M BARNABA 1/4/93	PRODUCT SPEC UL 486A	
APPLICATION SPEC	SIZE A3	CAGE CODE 00779
WEIGHT -	DRAWING NO G-53245	RESTRICTED TO -
CUSTOMER DRAWING		SCALE 4:1
		SHEET 1 OF 1
		REV L1